

SPECIFICATION

NO.:

Part No.: EG-5050-506V-A200-H1

Description: 5050 LED

Customer Approved		Approved	
Approved	Approved	Issued	
<input type="checkbox"/> Sample		<input checked="" type="checkbox"/> Mass Product	



RoHS
compliant

LM-80

LED light source
maintenance test
ENERGYSTAR

EYE

蓝光危害认证
EN62471/IEC TR 62778

Index

Features	2
Applications	2
Package Dimensions	3
Product coding rules.....	4
Electro Optical Characteristics (TA=25°C).....	5
Absolute Maximum Ratings (TA=25°C).....	6
Mass Production List	7
Spectral Distribution.....	8
Forward Voltage vs Forward Current	8
Relative Luminous vs Forward Current	9
Ambient Temperature vs Forward Current.....	9
Relative Flux vs Junction Temperature.....	10
View Angle Distribution.....	10
CIE Chromaticity Diagram: CIE.....	11
Color Rank	12
Packaging Specifications.....	15
Label	16
SMT Reflow Soldering Instructions	17
CARTIONS	18

◆ Features:

- * Small package with high efficiency
- * Low voltage operation, Instant light
- * Long operation life
- * Lead free product
- * RoHS compliant

◆ Applications:

- *Traditional lighting replacement
- *Ordinary lighting
- *Indoor&Outdoor sign board back light
- *Architectural / Decorative Lighting

EVERGLOW

◆ Package Dimensions

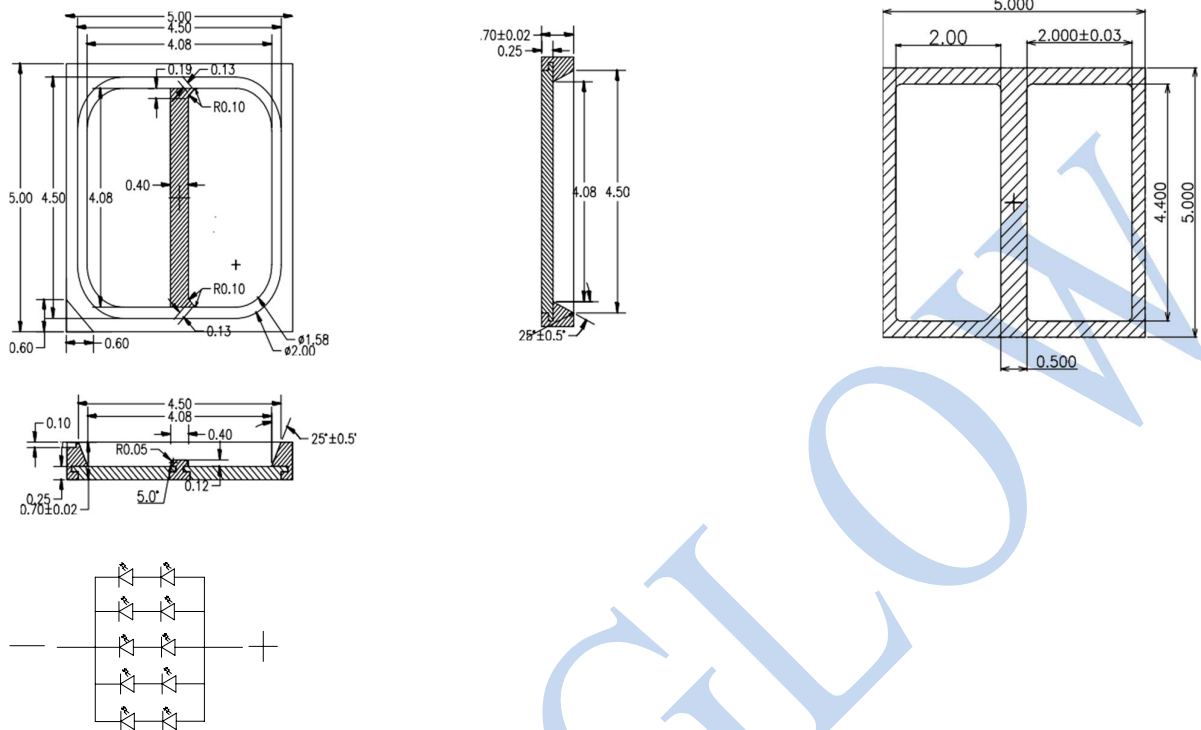

Soldering patterns

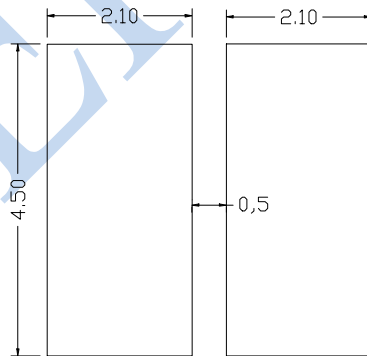

Notes:

1. All dimensions are in mm .
2. Tolerance is $\pm 0.15\text{mm}$ unless otherwise noted.

◆ Product coding rules

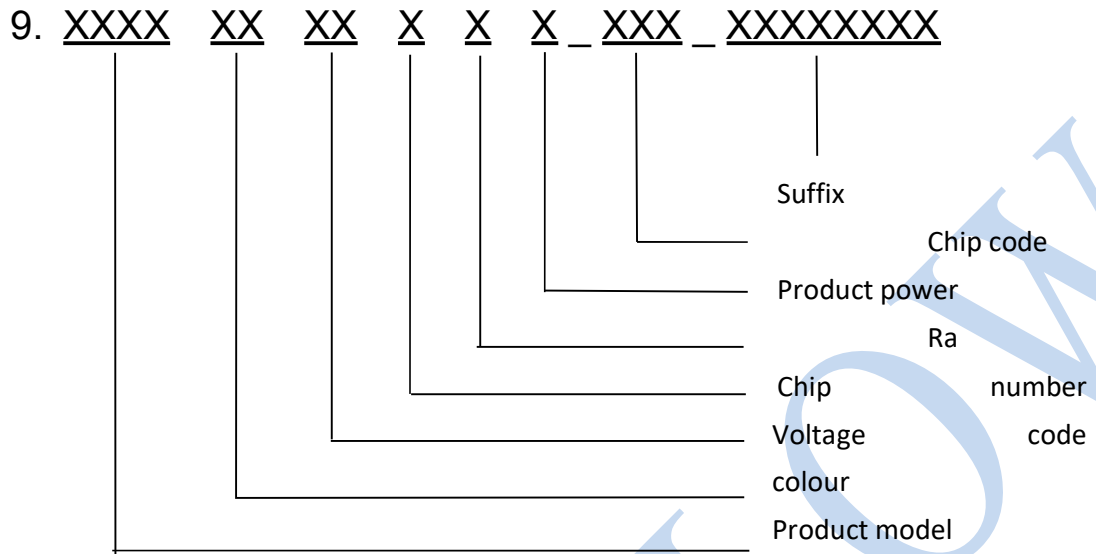

EVERGLOW

◆ Electro Optical Characteristics (TA=25 °C)

Parameter	Test Condition	Symbol	Min	Typ	Max	Unit
Forward Voltage	I _F =800mA	V _F	5.8	---	6.4	V
View Angle	I _F =800mA	2θ1/2	---	120	---	deg.
Electrostatic Discharge	HBM	ESD	---	---	2000	V
Color tolerance	I _F =800mA	SDCM	---	---	---	---

◆ Absolute Maximum Ratings ($T_A=25^{\circ}\text{C}$)

Parameter	Symbol	Rating	Unit
Forward Current	I_F	800	mA
Pulse Forward Current	I_{FP}	1100	mA
Power Dissipation	P_O	4800	mW
Reverse voltage	V_R	10	V
Operation temperature	T_{opr}	-40 to +85	$^{\circ}\text{C}$
Storage Temperature Range	T_{stg}	-40 to +85	$^{\circ}\text{C}$
Junction Temperature	T_j	125	$^{\circ}\text{C}$
Thermal resistance	R_{θ}	3.5	$^{\circ}\text{C}/\text{W}$
Soldering Temperature	T_{sld}	260 $^{\circ}\text{C}$ for 10sec	

Notes:

1. Frequency 10KHz, duty ratio $\leq 10\%$
2. The forward pulse current is the maximum current used by the chip at 25 $^{\circ}\text{C}$.

◆ Mass Production List (IF=800mA;TA=25°C)

Part NO.	Color Rendering index	CCT (K) Min	CCT (K) Typ	CCT (K) Max	Φ (lm) Min	Φ (lm) Max
EG-5050-506V-A200-H1	---	---	2050	---	600	700

Note: The test error

$V_F: \pm 2\%$

$XY: \pm 0.003$

$\Phi: \pm 10\%$

$R_a: \pm 1$

EVERGLOW

◆ Spectral Distribution

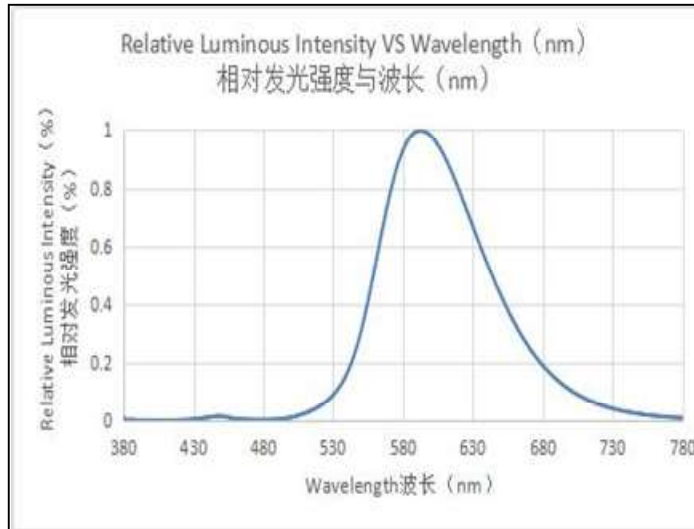

◆ Forward Voltage vs Forward Current

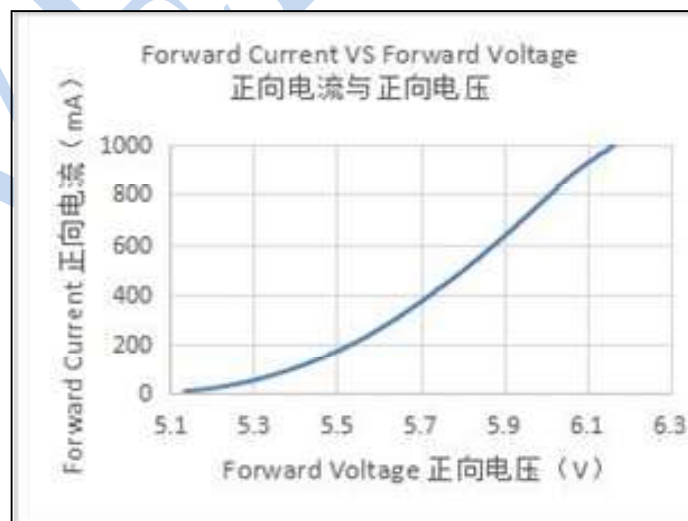

◆ **Relative Luminous vs Forward Current**

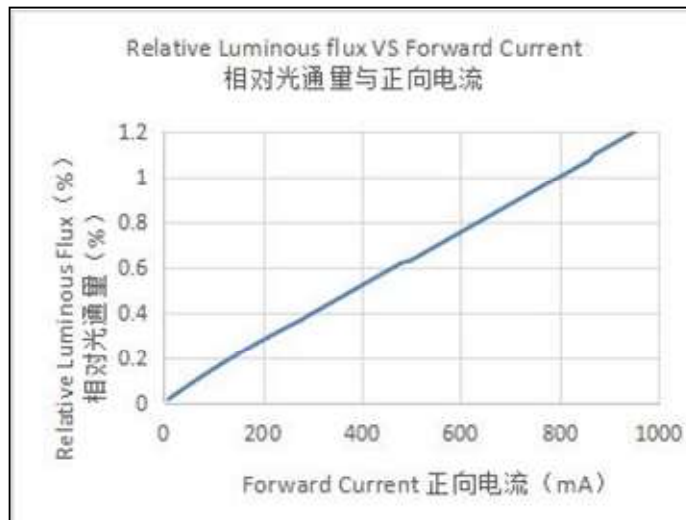

◆ **Ambient Temperature vs Forward Current**

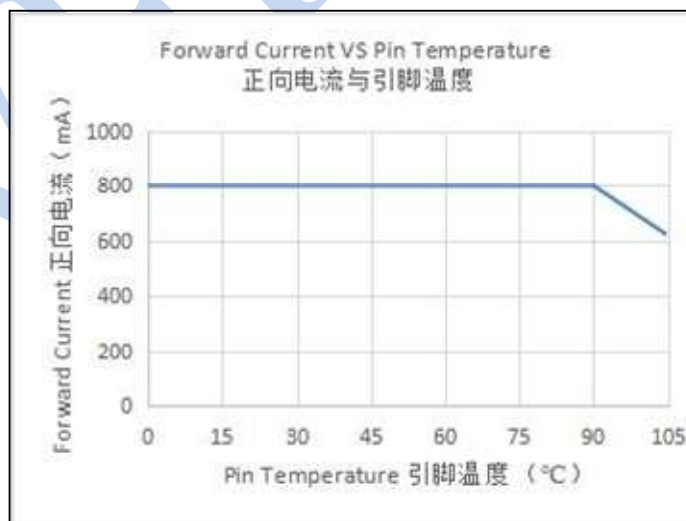

◆ **Relative Flux vs Junction Temperature**

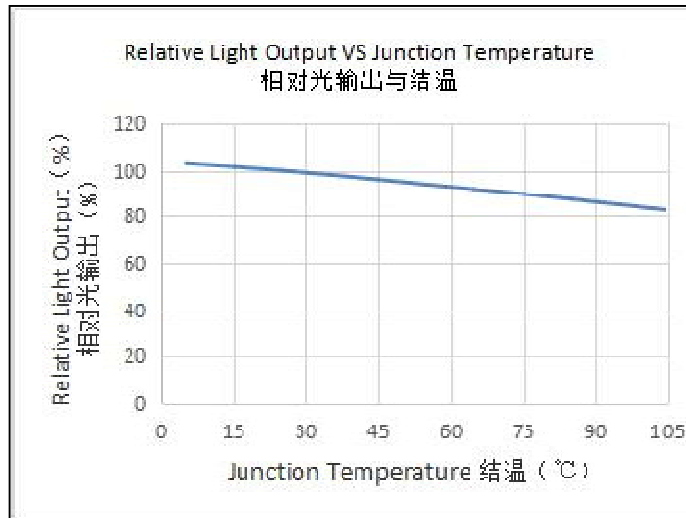

◆ **View Angle Distribution**

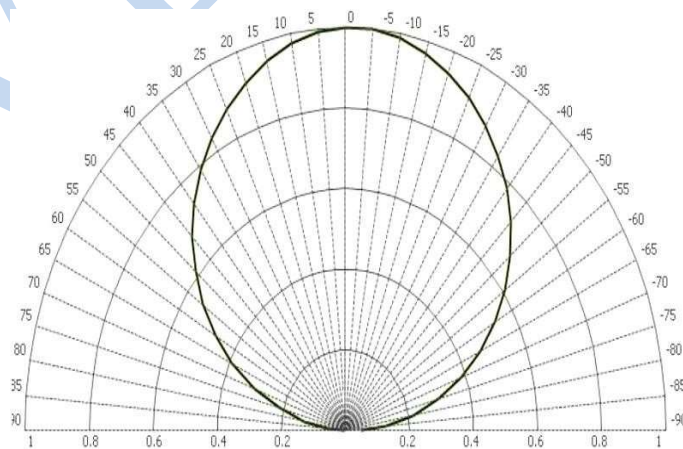

◆ CIE Chromaticity Diagram:(IF=800mA;TA=25 °C) CIE

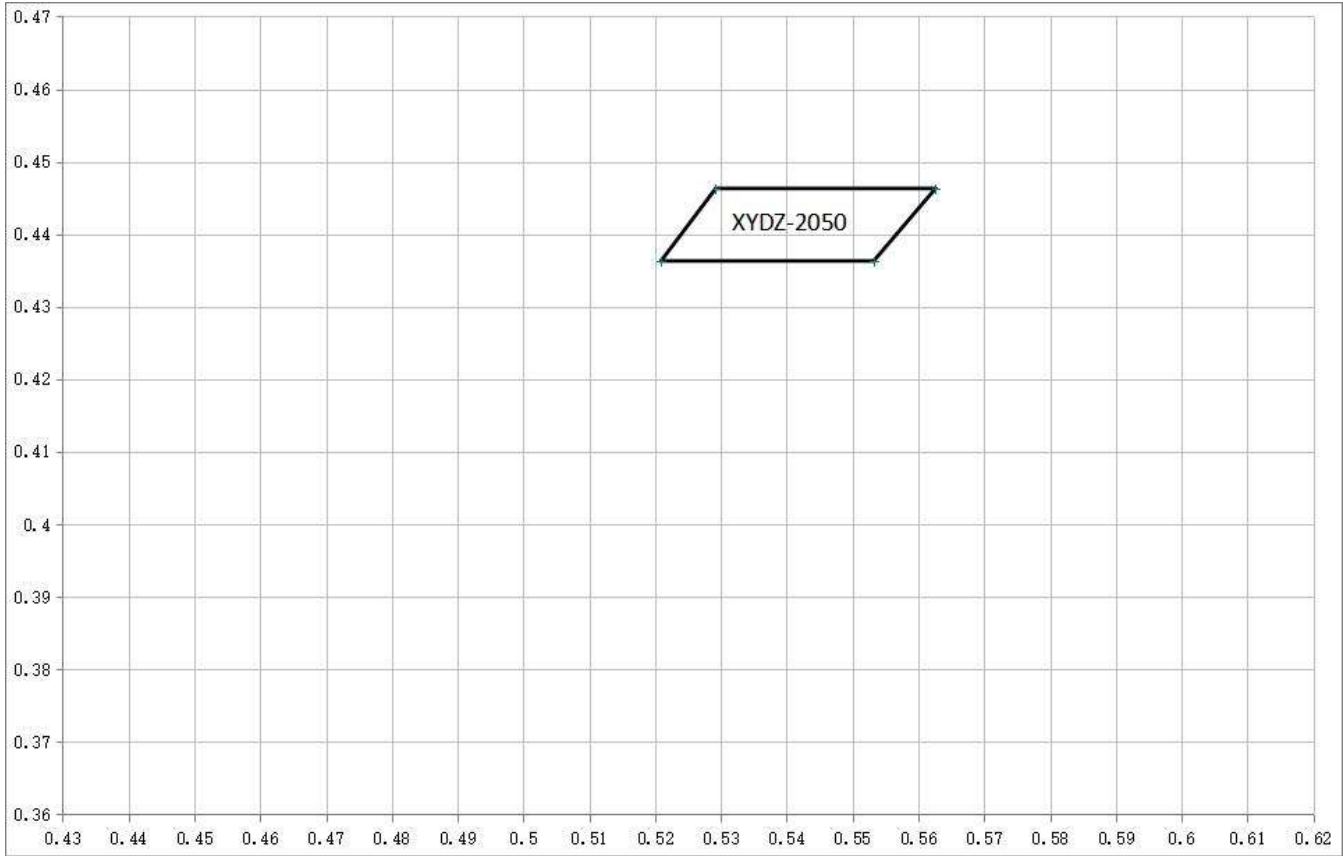

EVERGLOW

◆ Color Rank : (IF=800mA;TA=25°C)

CODE	CCT	X	Y
XYDZ-2050	---	0.5292	0.4463
		0.5209	0.4363
		0.5532	0.4363
		0.5626	0.4463

EVERGLOW

◆ Packaging Specifications

Dimensions of Tape

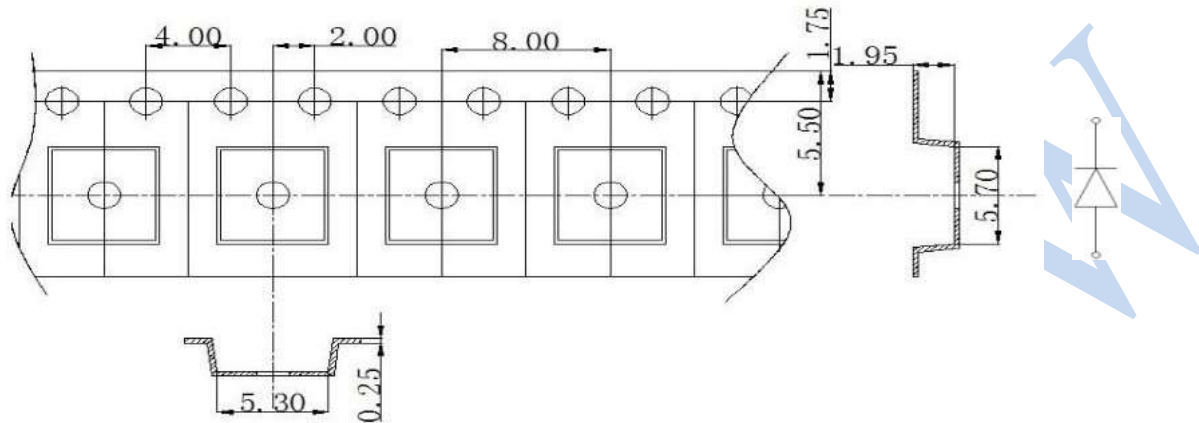

Dimensions of Reel

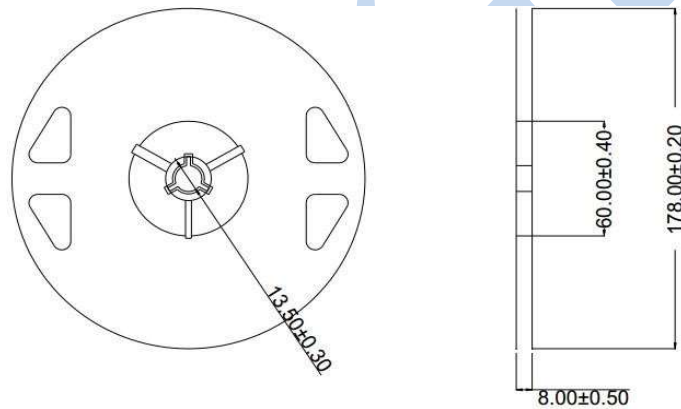

Packaging specifications

5050 EMC 2K

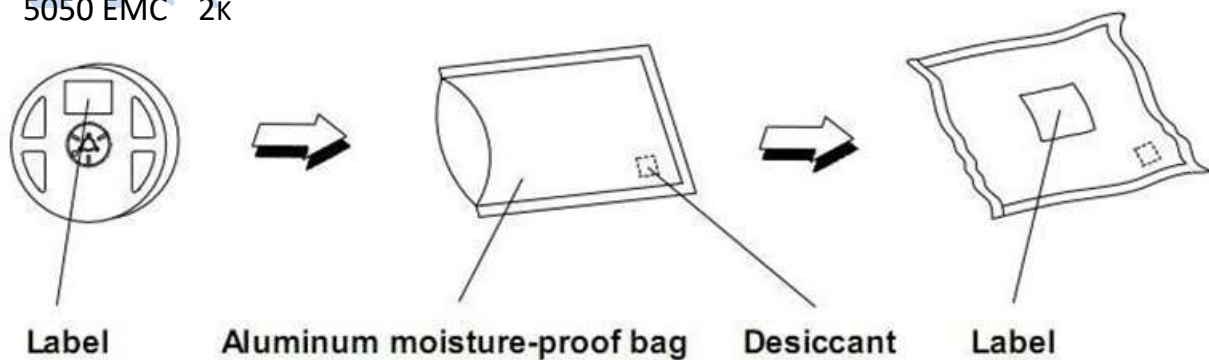

◆ Label:



P NO : EG-5050-506V-720-H1

Model : 5050 5W 6V 800mA

CCT : 1700-2000K

VF : 5.8-6.0 V

Color : Amber

QTY : 2000 Ra \geq 70

Lot No.:



Part NO: Product model

LOT NO: Instruction number

IV : Luminous flux

V_F/I_F: Voltage /Electric current

CCT/XY: Color temperature / Color Coordinates

Ra/SD/R9: Color Rendering index/Color tolerance /R9

Q'ty: Quantity

Date: Date

Code: Product code

◆ SMT Reflow Soldering Instructions SMT

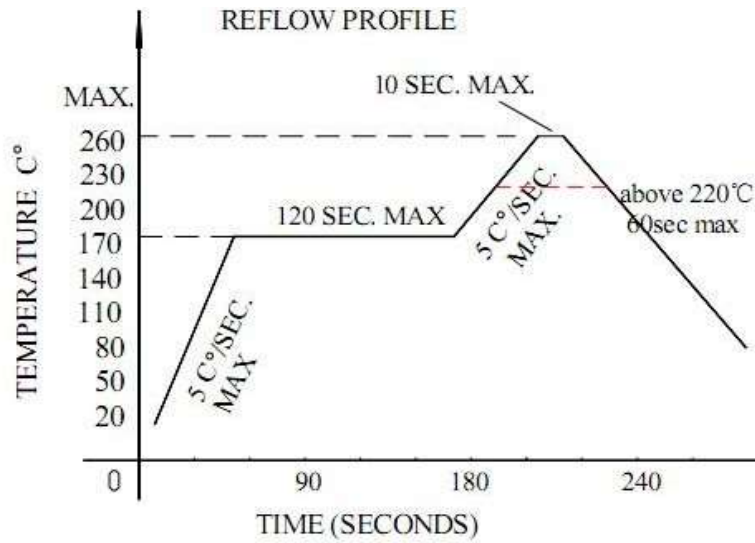

1. Reflow soldering should not be done more than two times
2. When soldering, do not put stress on the LEDs during heating

◆ CARTIONS

1, The encapsulated material of the LEDs is silicone. Therefore the LEDs have a soft surface on the top of package. The pressure to the top surface will be influence to the reliability of the LEDs. Precautions should be taken to avoid the strong pressure on the encapsulated part. So when use the picking up nozzle, the pressure on the silicone resin should be proper.

2, Compare to epoxy encapsulant that is hard and brittle, silicone is softer and flexible. Although its characteristic significantly reduces thermal stress, it is more prone to damage by external mechanical force . As a result, Special handling precautions must be observed during assembling using silicone encapsulated LED products, Failure to comply might leads to damage and premature failure of the LED.

①, Handle the component along the side surface by using forceps or appropriate tools; do not directly touch or Handle the silicone lens surface, it may damage the internal circuitry.

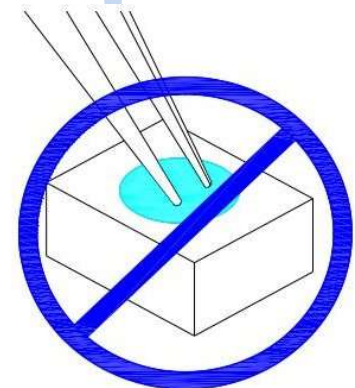
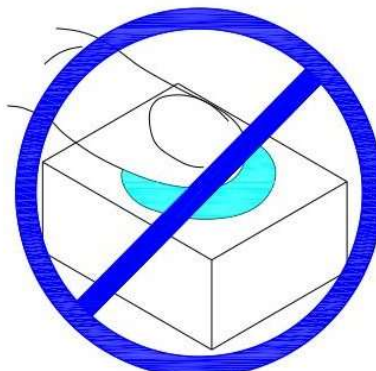
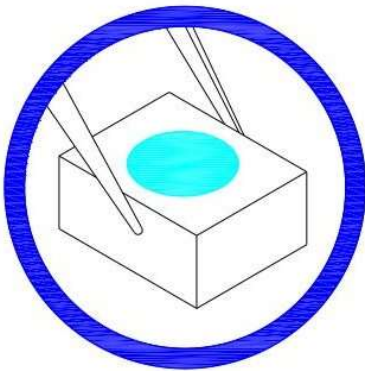

②, Do not stack together assembled PCBs containing LEDs. Impact may scratch the silicone lens or damage the internal circuitry.

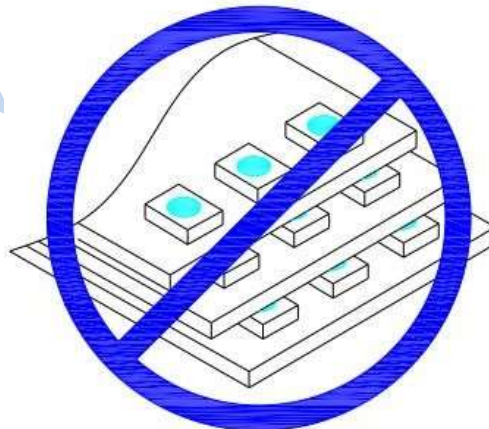

3, Material confirmation. Whether the LED Bin specifications of the material are consistent, such as whether V_F , XY, brightness and so on belong to the same specification, the same specification should be used together, if not the same specification LED is applied to the same object, it should be evaluated first, (if different V_F or XY cast together may produce difference in brightness or color).

4, Packaging and storage

4.1 Before opening packaging, avoid moisture entry into LED. SMD series LED is suggested to be stored in a drying cabinet with built-in desiccant. The storage environment is 5-30 centigrade, no more than 50% humidity. If storage time is over 3 months, LED needs to be re dehumidifying (65 degrees centigrade for more than /24 hours).

4.2 Open the precautions after packing. LED is a surface mount. When the LED is welded, the internal separation of LED may occur. The luminescence efficiency is affected and the luminance decreases or the color variation. The following are the matters to be paid attention to:

A, Before opening the package, please check the packaging bag for air leakage. If there is any air leakage, please return it to our company to re-bake the dehumidifying package before use.

B, After opening the package, welding should be completed as soon as possible (within 12 hours). C, The remaining materials are sealed or placed in an environment of 5~40 C and no more than 30% humidity.

D, If the open package is more than 24 hours (< 168 hours) or the humidity card is changed from blue to pink, LED needs to be dehumidifying again (65 degrees centigrade for more than /24 hours). If the package is opened for more than 168 hours, it is necessary to dismantle the tape and remove the moisture at 150°C /2h.

4.3, LED electrode and bracket are made of silver plated copper alloy. The silver layer on the surface

is easy to be affected by corrosive gases. Please avoid contacting with corrosive environment to cause LED discoloration, so as to avoid the poor weldability of LED and influence the photoelectric performance. Avoid sudden changes in temperature and humidity of the environment, especially under high humidity environment, easy to produce water vapor condensation.

5, Electrostatic protection. LED is a chip sensitive electronic component. Various measures should be taken to avoid static electricity, such as wearing an electrostatic bracelet or anti-static gloves during use. All devices, equipment and instruments should be well grounded.

EVERGLOW